

8 7 6 5 4 3 2 1

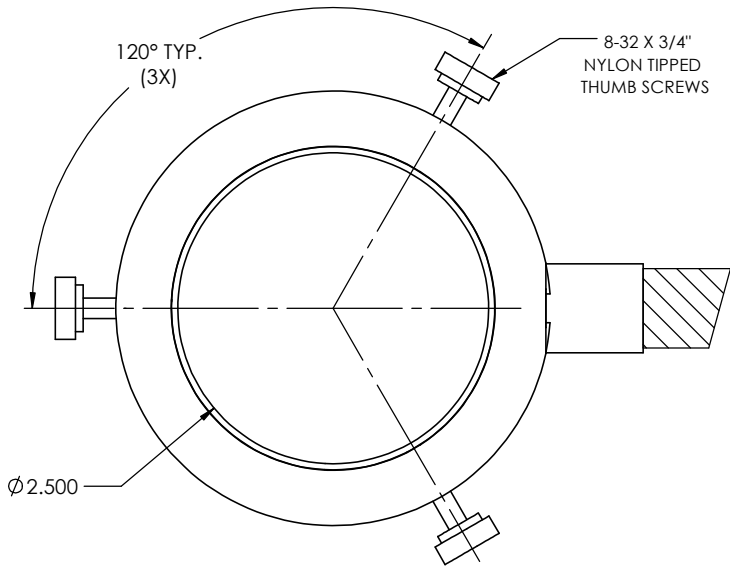

PART NUMBER	LENGTH "X"	SHEATHING	REV
FTIRL16856-2.5	30"	PVC COV'ED SL	C
FTIRL16856-2.5-36	36"	PVC COV'ED SL	B
FTIRL16856-2.5-1M	40"	PVC COV'ED SL	A
FTIRL16856-2.5-48	48"	PVC COV'ED SL	A
FTIRL16856-2.5-48-SL	48"	STST SL	A
FTIRL16856-2.5-72	72"	PVC COV'ED SL	A
FTIRL16856-2.5-144	144"	PVC COV'ED SL	-

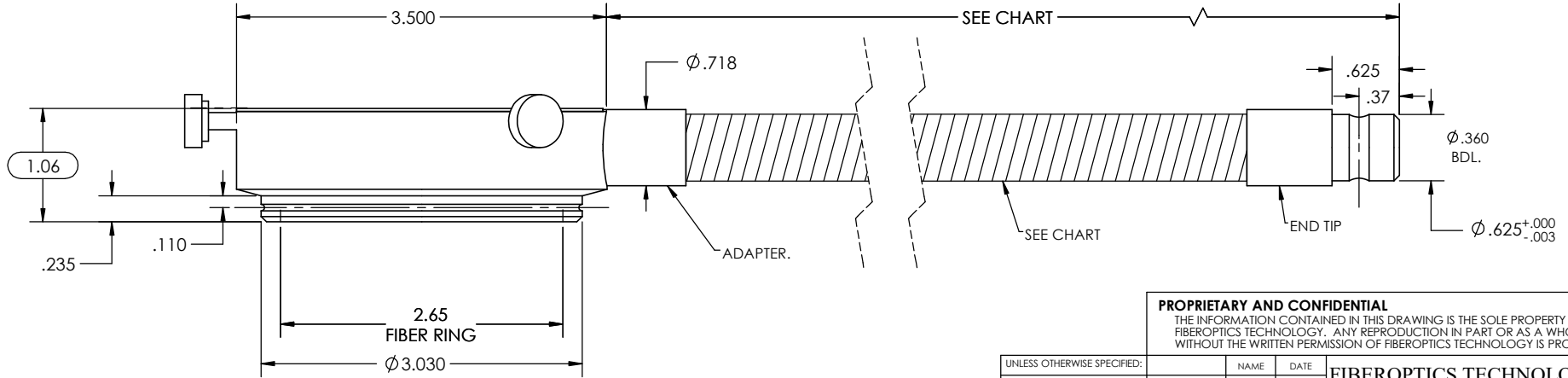

- NOTES:
- 1) FIBER - PureWave® XL55 OR SL55
 - 2) WORKING DISTANCE = 1.5" TO 6.0"
 - 3) RING LIGHT, ADAPTER AND END TIP-BLACK HARDCOAT ALUM.
 - 4) .010/.012 WIDE FIBER RING

PROPRIETARY AND CONFIDENTIAL
 THE INFORMATION CONTAINED IN THIS DRAWING IS THE SOLE PROPERTY OF FIBEROPTICS TECHNOLOGIES. ANY REPRODUCTION IN PART OR AS A WHOLE WITHOUT THE WRITTEN PERMISSION OF FIBEROPTICS TECHNOLOGIES IS PROHIBITED.

UNLESS OTHERWISE SPECIFIED:			NAME		DATE	FIBEROPTICS TECHNOLOGIES TITLE: 3.5" O.D. X 2.5" I.D. X "SEE CHART" RINGLIGHT
DIMENSIONS ARE IN INCHES			DRAWN	SGP	6/30/17	
TOLERANCES:			CHECKED	MH	7/10/17	
ANGULAR: MACH ±2°			ENG APPR.	MH	7/10/17	
TWO PLACE DECIMAL ±.010			MFG APPR.			
THREE PLACE DECIMAL ±.005			Q.A.			SIZE B DWG. NO. SEE CHART REV SEE CHART
INTERPRET GEOMETRIC TOLERANCING PER:			COMMENTS:			SCALE: 1:1
MATERIAL:						WEIGHT:
FINISH:						SHEET 1 OF 1
DO NOT SCALE DRAWING						

8 7 6 5 4 3 2 1